

IDEO®



BUS | LOCAL TRANSPORT



low-weight

ergonomically
designed

robust



IDEO®

The Ideo seat is especially created for daily use in urban traffic.

A prominent feature of the Ideo seat is the extremely thin and ergonomically-designed back which provides excellent sitting comfort and ample leg room.

The modular construction of this seat series offers a wide range of options.

The seat can be equipped with or without seat-and back cushions.



Product features and benefits:

- Low weight through the use of weight-optimized material
- Ergonomically shaped seat shell
- High modularity through various combination possibilities
- Quick-change system of upholstered parts
- Anti vandalism: The robust, solid-colored shell of PA-GF provides high vandalism and graffiti protection. The seat and back cushions are standard fully glued to the fabric and therefore offer a high protection against vandalism. The standard smooth back surface ensures easy removal of graffiti sprays.



DIMENSIONS

exemplary

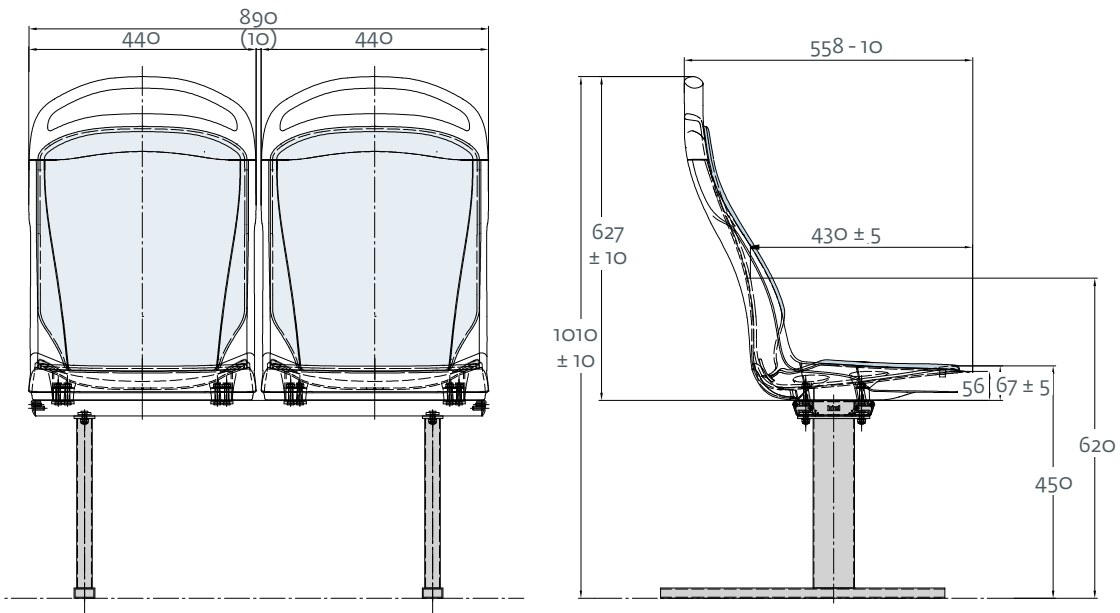

VERSIONS



Without bow-type handle



2-point bow-type handle



3-point bow-type handle



Armrest foldable



Mother-child seat



Back to back seating

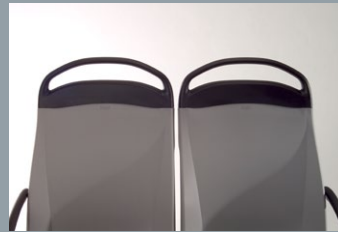

Cover with handle

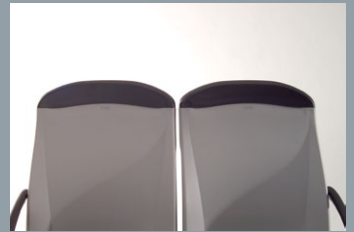

Standard cover



Ideo 10, without upholstery



Ideo 20, with seat cushion



Ideo 30, with seat- and backrest cushion

SEAT SHELL COLOUR OPTIONS



ruby red
RAL 3003



dusty grey
RAL 7037



brilliant blue
RAL 5007

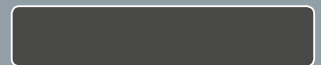

anthracite grey
RAL 7015

SPECIAL-PURPOSE SOLUTIONS ON REQUEST

- Seats for physically disabled
- Tip-up seat
- Foldable rear bank



PRODUCT OVERVIEW

SEAT TYPES

Single seat	<input checked="" type="checkbox"/>
Double seat	<input checked="" type="checkbox"/>
Tip-up seat	<input checked="" type="checkbox"/>
Mother-child seat	<input checked="" type="checkbox"/>
Back to back seating	<input checked="" type="checkbox"/>
Longitudinal seat	<input type="checkbox"/>
Lounge	<input type="checkbox"/>

DIMENSIONS

Single seat width	440 mm
Total seat width	880 mm

SPECIAL VERSIONS

Non-padded	<input checked="" type="checkbox"/>
Semi-padded	<input checked="" type="checkbox"/>
Full-padded	<input checked="" type="checkbox"/>

ACCESSORIES

Bow-type handle	<input checked="" type="checkbox"/>
Grasp handle	<input checked="" type="checkbox"/>
Armrest foldable	<input checked="" type="checkbox"/>
Stanchion fitting	<input type="checkbox"/>
Cantilever fixation	<input type="checkbox"/>

ANTIVANDALISM

Cut protection system	<input checked="" type="checkbox"/>
System kiel HR foam	<input checked="" type="checkbox"/>

WEIGHT

Double seat (standard version)	ca. 12 kg
--------------------------------	-----------

Compliant with legal requirements:
ECE-R118

Standard
 Option





Franz Kiel GmbH

Nürnberger Straße 62
86720 Nördlingen
Germany

Tel. +49 (0) 90 81/21 03 - 0
Fax +49 (0) 90 81/21 03 - 151

info@kiel-sitze.de
www.kiel-sitze.de

DRIVEN BY INNOVATION

