

Lite G4 Bus

Regional transport | modular + lightweight



Lite G4

modular + lightweight

The LITE G4 is the perfect seat for urban and regional buses: It is the lightest seat of its class – and with the largest possible modularity. Each component is connected with an innovative click system. This saves time and money during maintenance and repairs. The fact that the components of the LITE G4 can be replaced individually makes it especially environmentally friendly and robust. The components can also be recycled separately.

As the seating frame of the LITE G4 does not prescribe the height of the back rest, but instead the easily removable back cushion, it is possible to have different back rest heights. The material-saving modular design also has a positive impact on the weight: The LITE G4 weighs around 20 percent less than comparable models, making it the lightest seat in its class – this is also good for the environment, as less weight also means less fuel consumption. The automotive industry served us well for the design of the LITE G4: The seat resembles that of attractive, comfortable car seats and fits ideally into the ambience of modern urban and regional buses. With regard to covers, numerous different materials are available in addition to artificial and authentic leather, which is even made from recycled materials.



LITE G4 700



LITE G4 750

PRODUCT FEATURES AND BENEFITS

- Lightest seat of its class
- Modular, kit system
- Innovative click system
- Environmentally friendly + robust
- Components can be recycled separately

Lite G4 700

Functions

HANDLE

- Toward the aisle
- Optional

RIGID BACKREST

FOLDING ARMREST

- Toward the aisle
central

BOW-TYPE HANDLE

- Optional



HANDLE

- On the back
- Optional

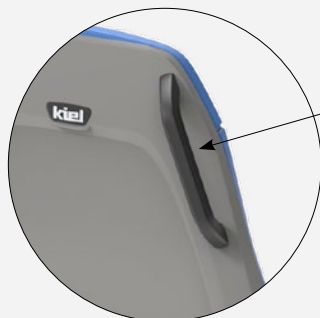

Lite G4 750

Functions

ADJUSTABLE BACKREST

- Left
- Optional

HANDLE

- Toward the aisle
- Optional

FOLDING ARMREST

- Toward the aisle central

BOW-TYPE HANDLE

- Optional



HANDLE

- On the back
- Optional

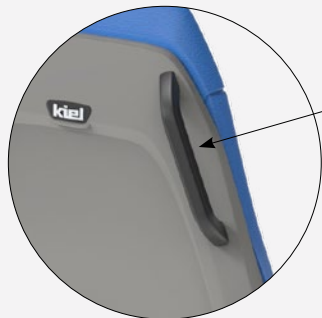

Lite G4 700

Illustrative dimensions

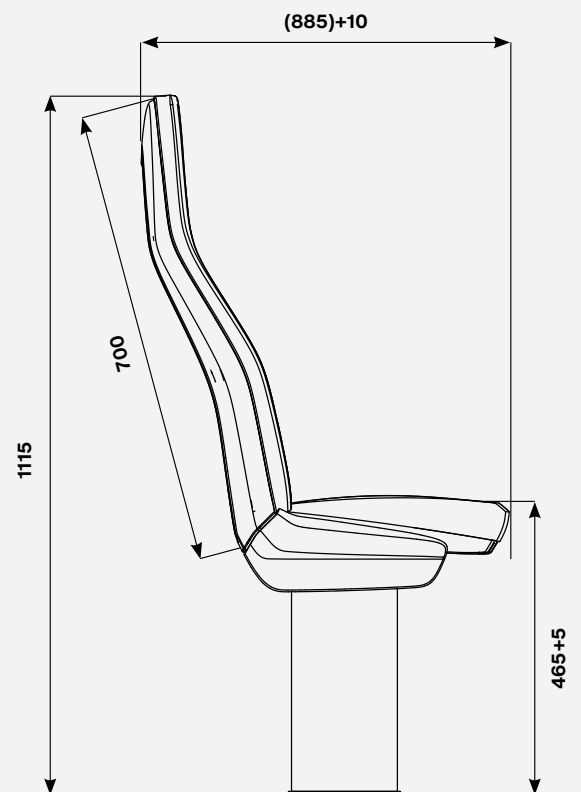
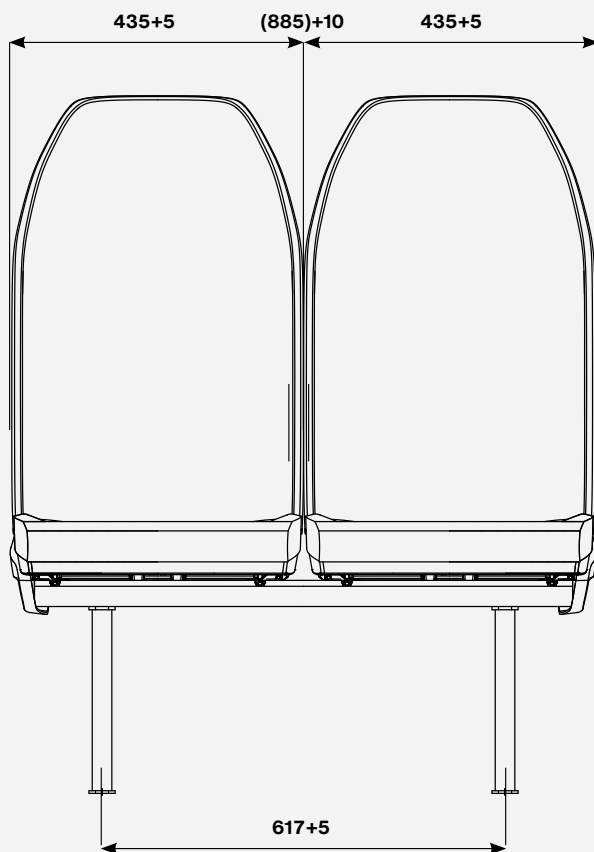

Lite G4 750

Illustrative dimensions

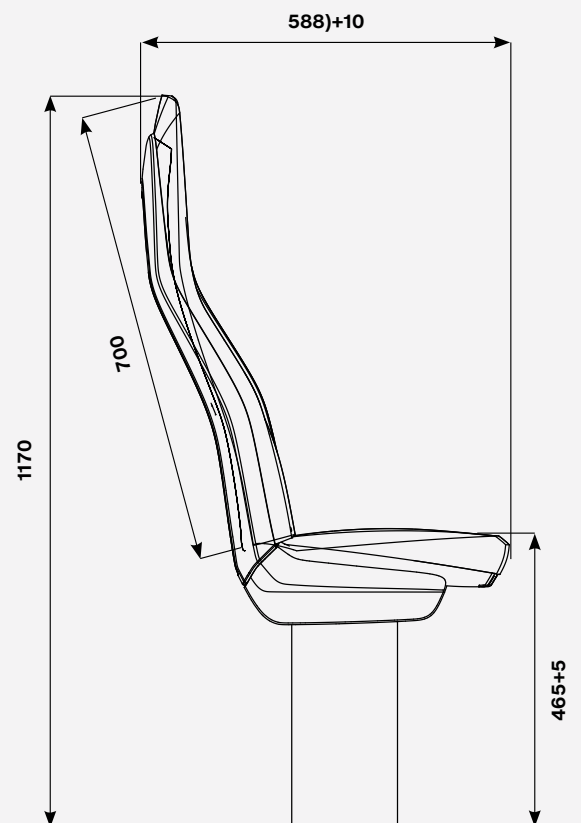
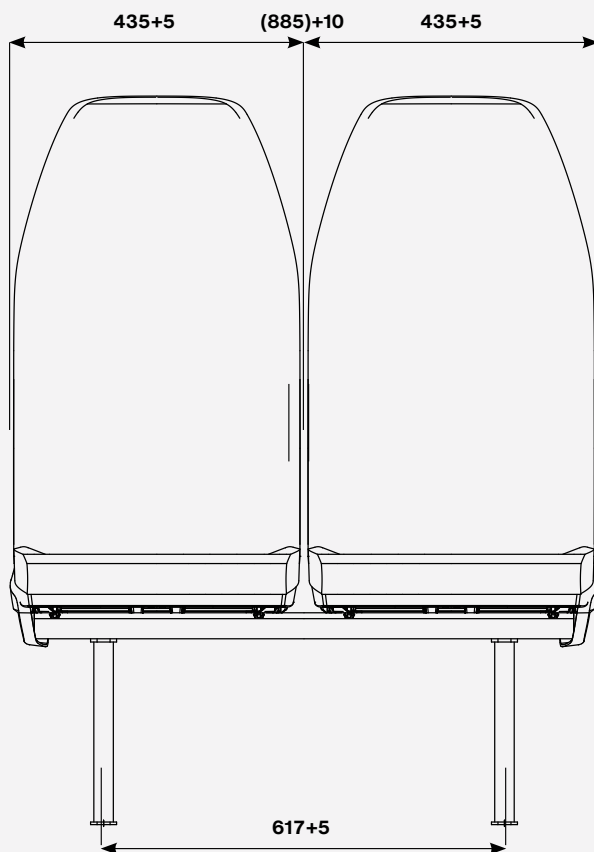

Lite G4 700/750

Product overview

CLASSIFICATION	LITE G4 700	LITE G4 750
Single seat	<input type="checkbox"/>	<input type="checkbox"/>
Double seat	<input checked="" type="checkbox"/>	<input checked="" type="checkbox"/>
Tip-up seat	<input type="checkbox"/>	<input type="checkbox"/>
Back to back seating	<input type="checkbox"/>	<input type="checkbox"/>
3er Sitzkombination	<input type="checkbox"/>	<input type="checkbox"/>
Longitudinal seat	<input type="checkbox"/>	<input type="checkbox"/>
DIMENSIONS		
Dimensions	435 mm	435 mm
Total seat width	885 mm	885 mm
FEATURES		
Backrest fixed	<input checked="" type="checkbox"/>	<input checked="" type="checkbox"/>
Backrest adjustable	n/a	<input type="checkbox"/>
RESTRAINT SYSTEM		
2-point safety belt	n/a	<input type="checkbox"/>
3-point safety belt	n/a	<input type="checkbox"/>
Belt hook for children/juveniles	n/a	<input type="checkbox"/>
ACCESORIES		
Bow-type handle	<input type="checkbox"/>	<input type="checkbox"/>
Armrest foldable	<input type="checkbox"/>	<input type="checkbox"/>
Grasp handle/handle on back (horizontal)	<input type="checkbox"/>	<input type="checkbox"/>
Footrest adjustable	<input type="checkbox"/>	<input type="checkbox"/>
Magazine net	<input type="checkbox"/>	<input type="checkbox"/>
School handle	<input type="checkbox"/>	<input type="checkbox"/>
Stanchion fitting	<input type="checkbox"/>	<input type="checkbox"/>
USB on the backrests	<input type="checkbox"/>	<input type="checkbox"/>
Stop button	<input type="checkbox"/>	<input type="checkbox"/>
Table	<input type="checkbox"/>	<input type="checkbox"/>
Reading light	<input type="checkbox"/>	<input type="checkbox"/>
Phone holder	<input type="checkbox"/>	<input type="checkbox"/>
Cup holder	<input type="checkbox"/>	<input type="checkbox"/>
Cantilever-fixation	<input type="checkbox"/>	n/a
Full backrest cover	<input type="checkbox"/>	<input type="checkbox"/>
Seat cushions standard (h= 90 mm)	<input checked="" type="checkbox"/>	<input checked="" type="checkbox"/>
seat cushions high (h=125 mm)	<input type="checkbox"/>	<input type="checkbox"/>
WEIGHT		
Double seat (standard) without belts	ca. 17.5 kg	ca. 26 kg
Double seat (standard) with 2-p./3-p. belts		ca. 21/25.5 kg
Legal requirements: EN 45545/GOST/UIC 566/Grula DB		
<input checked="" type="checkbox"/> standard <input type="checkbox"/> optional n/a not available		

